

Motor Series **MTS8c**

Stepper Motor 11.25°



Standard Data

Motor type		Permanent Magnet (PM) stepper motor
Electrical Enclosure	IP	40
Connections		Flexible Leads 22 AWG, 200mm length; ends stripped 10 mm
Duty Cycle		Continuous
Weight	g	450
Mounting		Any position by ears or screw clip

Dimensional Drawing

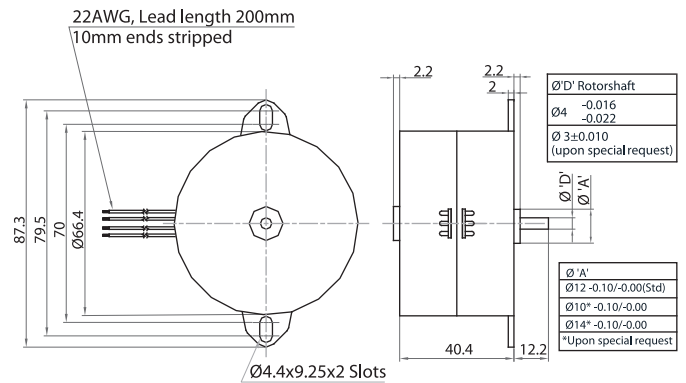

Technical Data

Steps per revolution		32	
Degree/step		11.25	
Winding Type		bipolar	
Standard Voltage	V	4.5	
Resistance per winding	Ω	4.0	
Winding Temperature	°C	130 max	
Magnet Type		(MTSB8c) Regular	(MTSB8c-RE) Strong
Holding torque	Ncm	30	45
Axial Force	N	6	6
Lateral Force	N	15	15
Detent Torque	Ncm	2	7.5
Rotor inertia	gcm ²	155	180

Ordering Data (eg.)

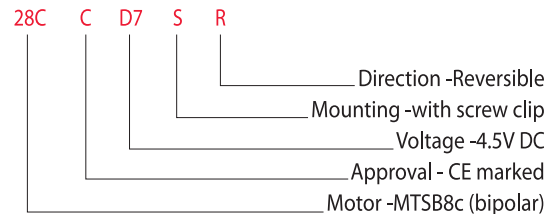

Torque Graphs

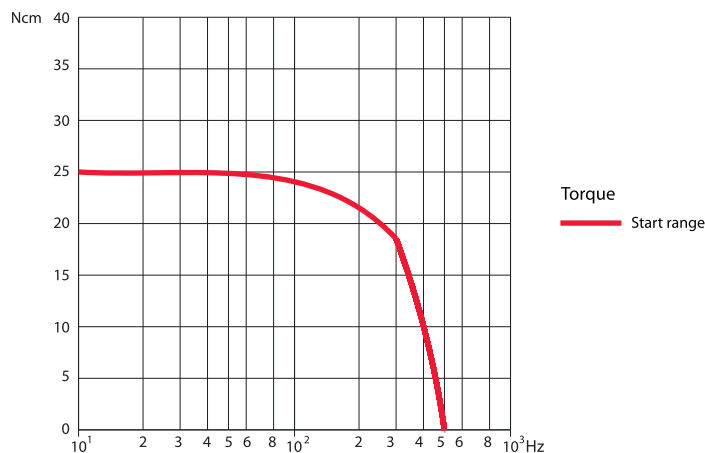

Regular magnet Start range (pull-in) with constant current power stage (chopper Drive)

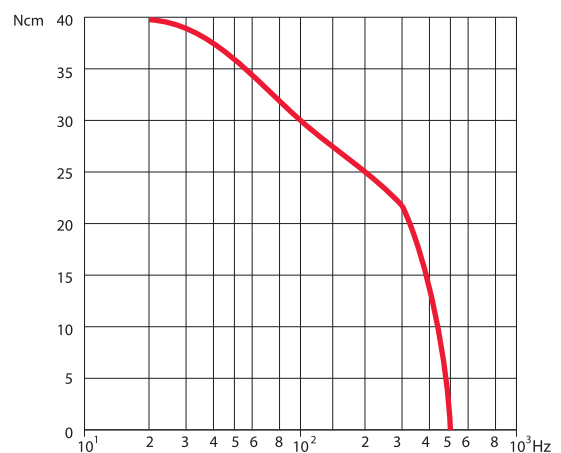

Strong Magnet Start range (pull-in) with constant current power stage (chopper Drive)