

Motor Series MTS3b

Stepper Motor 15°



Standard Data

Motor type		Permanent Magnet (PM) stepper motor
Electrical Enclosure	IP	40
Connections		Flexible Leads 26 AWG, 200mm length; ends stripped 10 mm
Life expectancy		3 years in continuous operation
Weight	g	65
Mounting		Any position by ears or screw clip

Technical Data

Steps per revolution		24			
Degree/step		15			
Winding Type		bipolar			
Standard Voltage	V	3	6	12	24
Resistance per winding	Ω	11.5	18.5	100	460
Winding Type		unipolar			
Standard Voltage	V	3	6	12	24
Resistance per winding	Ω	12	28.5	120	500
Winding temperature	$^{\circ}\text{C}$	105 max.			
Holding torque	Ncm	1.4	(MTSB3b)	1	(MTSU3b)
Axial Force	N	1			
Lateral Force	N	3			
Rotor inertia	gcm^2	2.9			

Dimensional Drawing

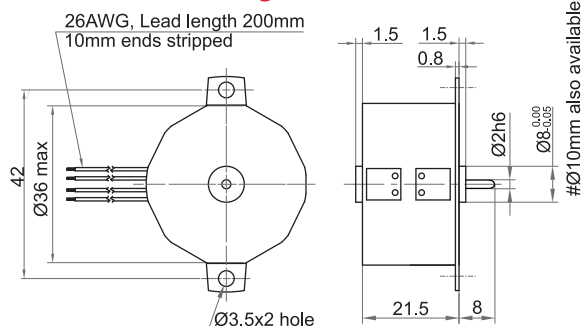

Ordering Data (eg.)

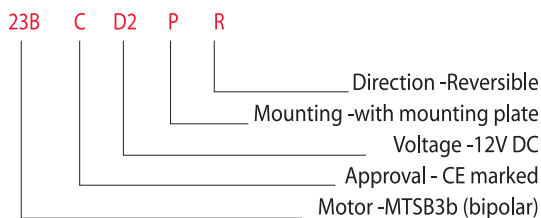

Torque Graphs

Start range (pull-in) with constant voltage power stage

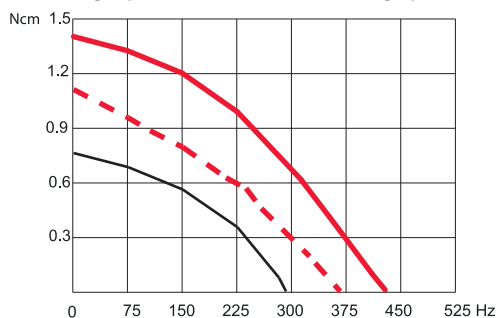

2-Phase stepper Motor MTSB3b

Start range (pull-in) with constant voltage power stage

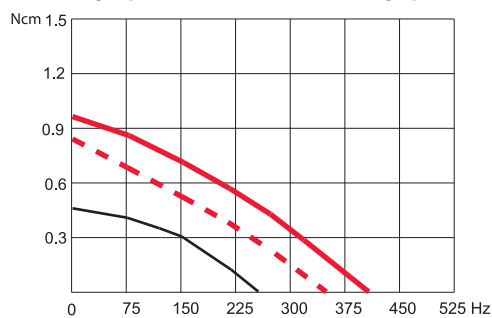

4-Phase Stepper Motor MTSU3b

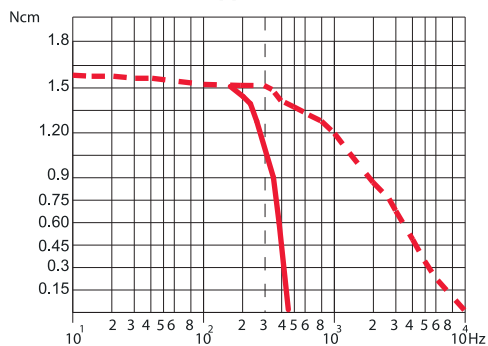

Slew range (pull-out) and start range (pull-in) with constant current power stage (chopper Drive)

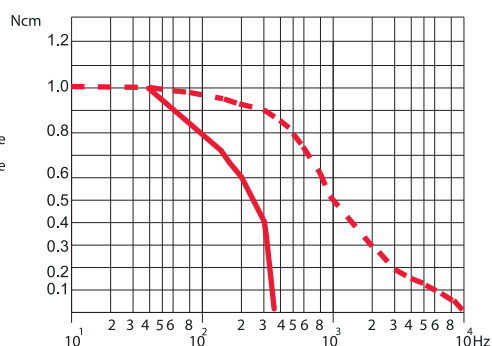

Slew range (pull-out) and start range (pull-in) with constant current power stage (chopper Drive)